



MOP-TFT320102-29A-BLM-TPN

Hardware Manual

Revision 1.1

Revision History

Revision	Date	Description	Author
1.1	June 13, 2017	Updated TBD Weight information	Divino
1.0	May 26, 2017	Initial Release	Divino



Contents

- Revision History1
- Contents2
- 1 General Information3
- 2 Absolute Maximum Ratings.....3
- 3 Electrical Characteristics.....3
- 4 External Dimensions4
- 5 Electro-Optical Characteristics5
- 6 Interface Description6
 - 6.1 LCM Interface Description6
- 7 AC Characteristics7
 - 7.1 Pixel Timing.....7
 - 7.2 Data Timing.....8
 - 7.3 Signal Timing in DE Mode9
- 8 Power Sequence10
 - 8.1 Power Up Sequence10
 - 8.2 Power Down Sequence.....11
- 9 Inspection Criterion12
 - 9.1 Description12
 - 9.2 Sample plan12
 - 9.3 Inspection condition.....12
 - 9.4 Definition of inspection zone in LCD.....12
 - 9.5 Function Defect12
 - 9.6 LCD pixel defect13
 - 9.7 Dot and line defect13
- 10 Handling Precautions.....14
 - 10.1 Mounting method14
 - 10.2 LCD Handling and Cleaning Precaution14
 - 10.3 Static Charge Precaution14
 - 10.4 Packing.....14
 - 10.5 Precautions during Operation14
 - 10.6 Storage Recommendations15
 - 10.7 Safety Precautions15
- 11 Ordering16
 - 11.1 Part Numbering Scheme.....16
 - 11.2 Options16
- 12 Contact16



1 General Information

No.	Item	Contents	Unit
1	Outline Dimensions	76.9(W) * 36.0(H) * 3.2(D)	mm
2	Display Size	2.89	inch
3	Dot Pitch	0.219mm * 0.219mm	mm
4	Number of Dots	320*(RGB)*102	-
5	Driver IC	HX8238D	-
6	LCD Type	TN/Transmissive	-
7	Interface	RGB 24 bit	-
8	Backlight Type	LED White	-
9	Viewing Direction	6 O'clock	-
10	Weight	18	g

2 Absolute Maximum Ratings

Item	Symbol	Min	Max	Unit
Power Supply for Pump	VCC	-0.3	3.6	V
Operating temperature range	To	-20	70	Degree C
Storage temperature range	Ts	-30	80	Degree C
Logic input voltage range	VI	-0.3	VCC+0.3	V
Logic output voltage range	VO	-0.3	VV+0.3	V

3 Electrical Characteristics

DC Characteristics (at Ta=25 °C)

Item	Symbol	Min	Typ	Max	Unit	Conditions
System power supply pins of the logic block	VDD	1.6	-	2.5	V	
Power supply pins of IO pins	VDDIO	1.6	-	3.6	V	
Booster Reference Supply Voltage Range	VCI	2.5 or VDDIO	-	3.6	V	
High Level Output Voltage	Voh	0.9VDDIO	-	VDD	V	Iout = -100A
Low Level Output Voltage	Vol	GND	-	0.1VDDIO	V	Iout = 100A
High Level Input Voltage	Vih	0.8VDDIO	-	VDDIO	V	
Low Level Input Voltage	Vil	GND	-	0.2VDDIO	V	
Input Leakage Current	Iil		-	±1.0	µA	
Pull High/Low Resistor	Rp	-	100K	-	ohm	



4 External Dimensions

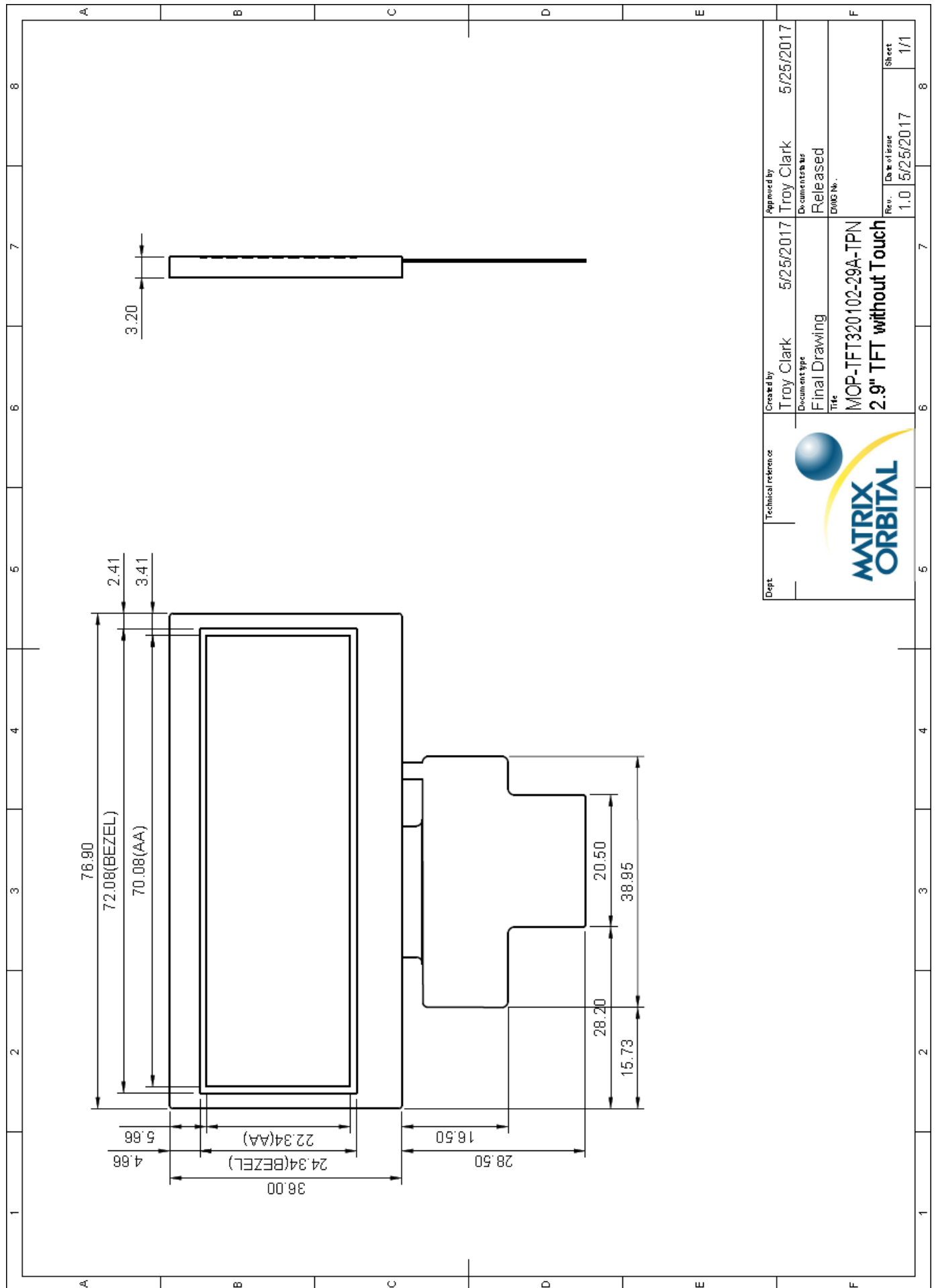

Figure 1: MOP-TFT320102-29A-BLM-TPN Drawing



5 Electro-Optical Characteristics

Item	Symbol	Condition	Min	Typ	Max	Unit	Remark
Transmittance	T		6.7	7.2		%	
Contrast Ratio	CR	*1)	300	500		-	Note 3
Surface Luminance	LV			400		Cd/m ²	
Response Time	Tr+Tf	*2)	-	25	40	ms	Note 4
Viewing Angle	Vertical	U	CR ≥ 10		75	-	
		D			75	-	
	Horizontal	L			75	-	
		R		φ*2)		75	-
Color Filter Chromaticity	White	x	θ = φ = 0°	0.285	0.305	0.325	
		y		0.314	0.334	0.354	
		Y		29.9	32.9	35.9	
	Red	x	θ = φ = 0°	0.588	0.608	0.628	
		y		0.296	0.316	0.336	
		Y		17.8	20.8	23.8	
	Green	x	θ = φ = 0°	0.285	0.305	0.325	
		y		0.536	0.556	0.576	
		Y		57.4	61.4	65.4	
	Blue	x	θ = φ = 0°	0.125	0.135	0.155	
		y		0.117	0.137	0.157	
		Y		13.2	16.2	19.2	
NTSC			-	53%	-		

*Note 1: Ambient condition: 25°C±2°C, 60±10%RH, under 10 Lux in the darkroom

*Note 2: Measure device: BM-5A(TOPCON), viewing cone = 1°, IL = 20mA

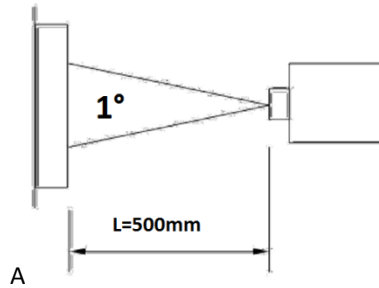

*Note 3: Measure device: BM-5A(TOPCON), viewing cone = 1°, IL = 20mA

$$CR = \frac{\text{White Luminance(On)}}{\text{Black Luminance(Off)}}$$

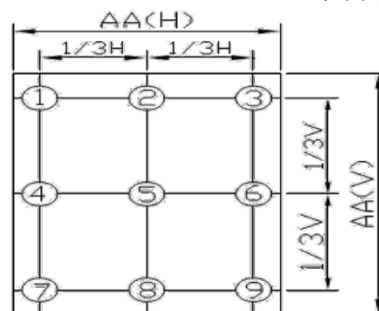

*Note 4: Definition of response time: The response time is defined as the time interval between the 10% and 90% amplitudes.



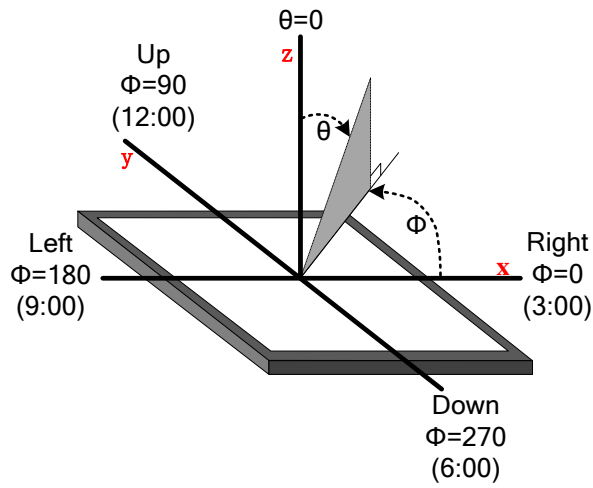

Figure 2: The definition of viewing angle

6 Interface Description

6.1 LCM Interface Description

Interface No.	Name	I/O Pin Connections	Description
1	LEDK	I	Power for LED backlight(Cathode)
2	LEDA	I	Power for LED backlight(Anode)
3	GND	P	Power Ground
4	VCC	P	Power Source
5-12	R0~R7	I	Red Data Signal
13-20	G0~G7	I	Green Data Signal
21-28	B0~B7	I	Blue Data Signal
29	GND	P	Power Ground
30	CLK	I	Clock signal to sample each data
31	DISP	-	Display on/off signal. DISP="H" Display on; DISP="L" Display off
32	HSYNC	I	Horizontal Synchronizing Signal
33	VSYNC	I	Vertical Synchronizing Signal
34	DEN	I	Input Data Enable Control
35	NC	-	No connection
36	GND	P	Power Ground
37	XR(NC)	-	No Connection
38	YD(NC)	-	No Connection
39	XL(NC)	-	No Connection
40	YU(NC)	-	No Connection

*Note: I = Input, O=Output, P=Power

7 AC Characteristics

7.1 Pixel Timing

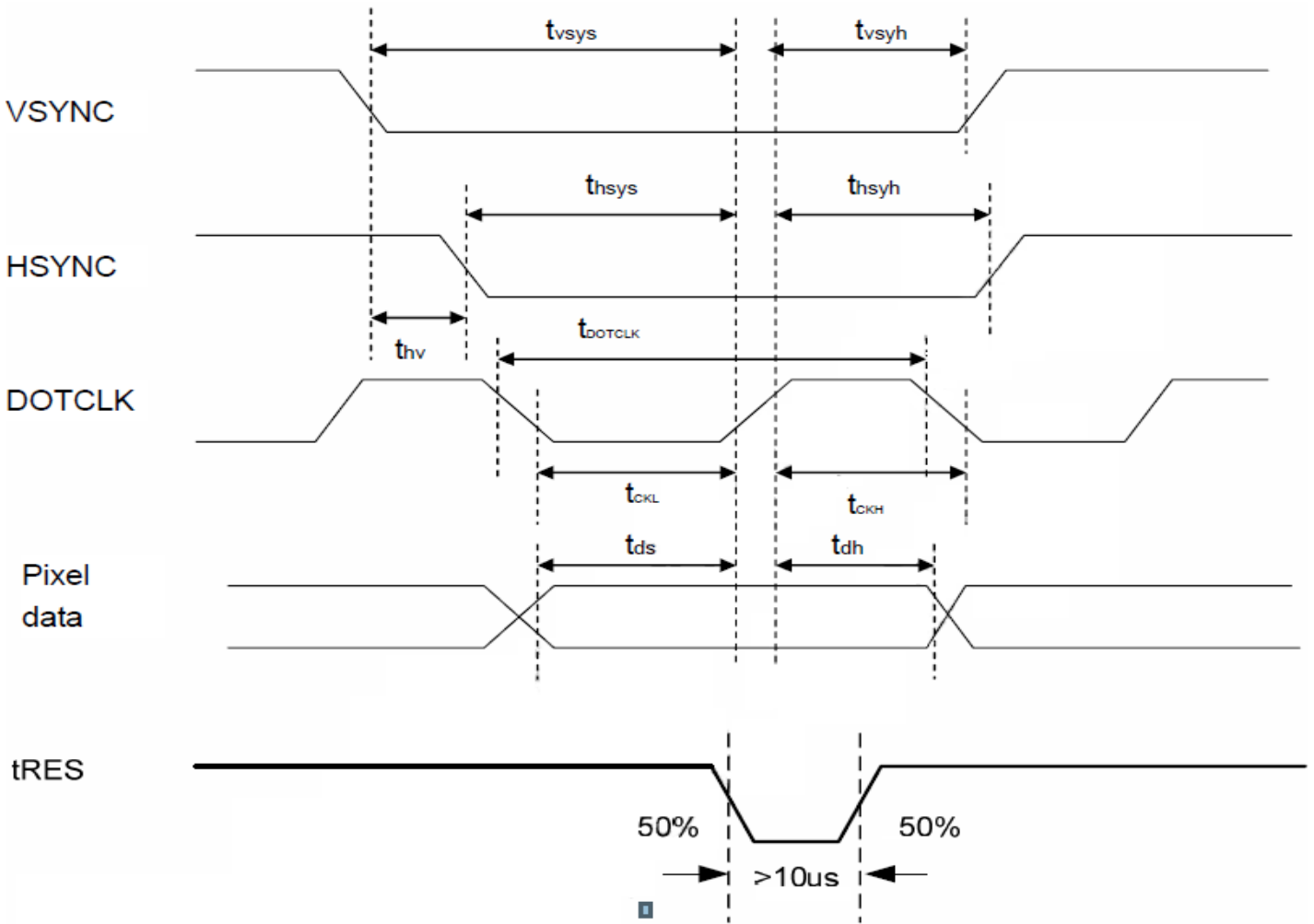

Figure 3: Pixel Timing

Characteristics	Symbol	Min.		Typ.		Max.		Unit
		24 bit	8 bit	24 bit	8 bit	24 bit	8 bit	
DOTCLK Frequency	fDOTCLK	-	-	6.5	19.5	10	30	MHz
DOTCLK Period	tDOTCLK	100	33.3	154	51.3	-	-	ns
Vertical Sync Setup Time	tvsys	20	10	-	-	-	-	ns
Vertical Sync Hold Time	tvsyh	20	10	-	-	-	-	ns
Horizontal Sync Setup Time	thsys	20	10	-	-	-	-	ns
Horizontal Sync Hold Time	thsyh	20	10	-	-	-	-	ns
Phase Difference of Sync Signal Falling Edge	thv	1		-		240		tDOTCLK
DOTCLK Low Period	tCKL	50	15	-	-	-	-	ns
DOTCLK High Period	tCKH	50	15	-	-	-	-	ns
Data Setup Time	tds	12	10	-	-	-	-	ns
Data Hold Time	tdh	12	10	-	-	-	-	ns
Reset pulse width	tRES	10		-		-		μs

*Note: External clock source must be provided to DOTCLK pin of HX8238-D. The driver will not operate if absent of the clocking signal.



7.2 Data Timing

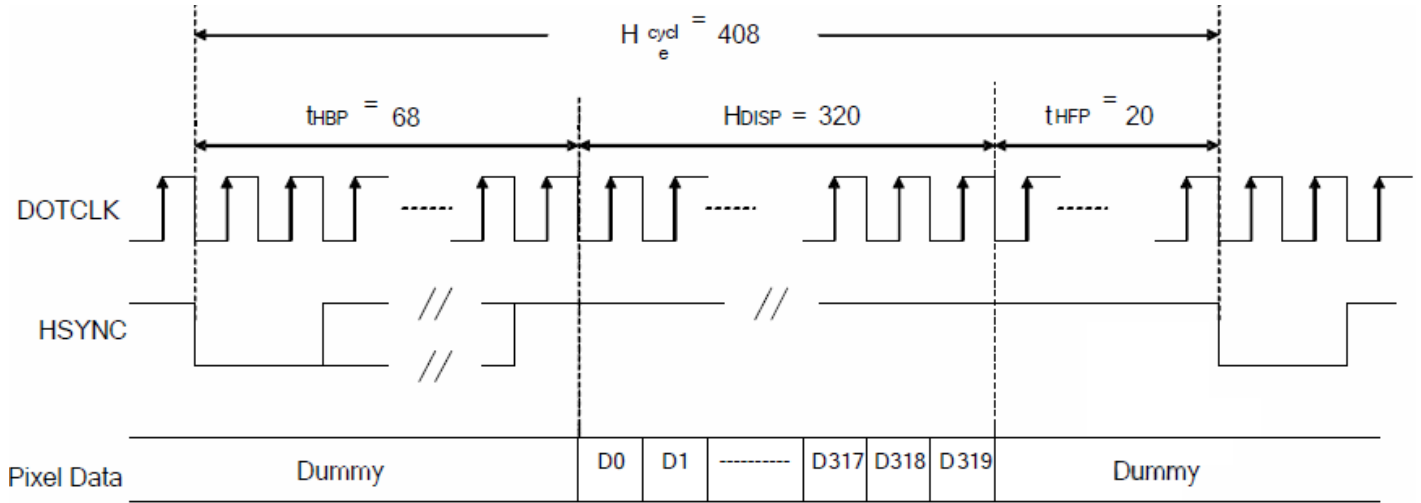

(a) Horizontal Data Transaction Timing

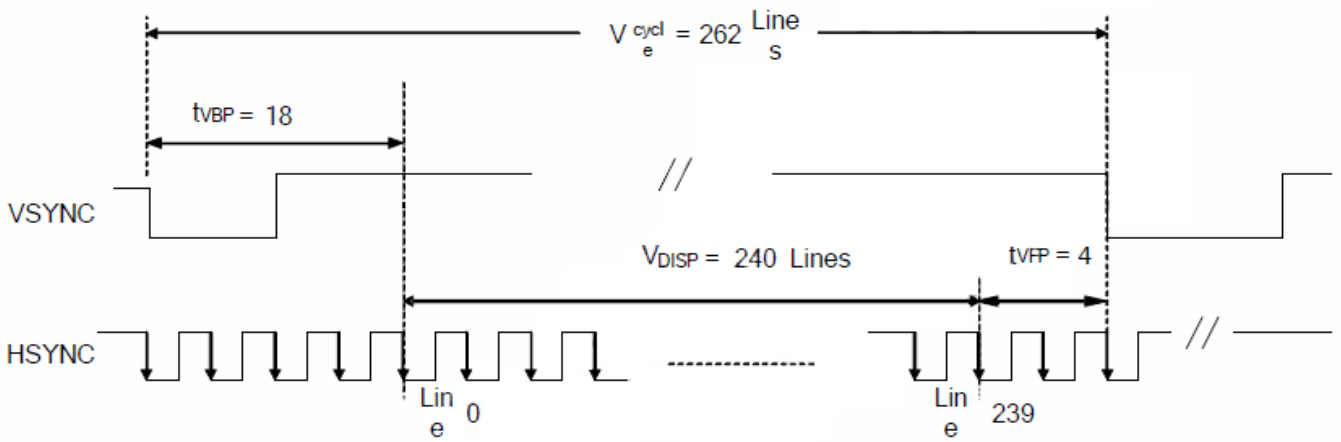

(b) Vertical Data Transaction Timing

Figure 4: Data Transaction Timing in Parallel RGB (24Bit) interface (SYNC Mode)

Characteristics	Symbol	Min.		Typ.		Max.		Unit
		24 bit	8 bit	24 bit	8 bit	24 bit	8 bit	
DOTCLK Frequency	fDOTCLK	-	-	6.5	19.5	10	30	MHz
DOTCLK Period	tDOTCLK	100	33.3	154	51.3	-	-	ns
Horizontal Frequency (Line)	fH	-	-	14.9	-	22.35	-	KHz
Vertical Frequency (Refresh)	fV	-	-	60	-	90	-	Hz
Horizontal Back porch	tHBP	-	-	68	204	-	-	tDOTCLK
Horizontal Front porch	tHFP	-	-	20	60	-	-	tDOTCLK
Horizontal Data Start Point	tHBP	-	-	68	204	-	-	tDOTCLK
Horizontal Blanking Period	tHBP + tHFP	-	-	88	264	-	-	tDOTCLK
Horizontal Display Area	H_DISP	-	-	320	960	-	-	tDOTCLK
Horizontal Cycle	Hcycle	-	-	408	1224	450	1350	tDOTCLK
Vertical Back Porch	tVBP	-	-	18	-	-	-	Lines
Vertical Front Porch	tVFP	-	-	4	-	-	-	Lines
Vertical Data Start Point	tVBP	-	-	18	-	-	-	Lines
Vertical Blanking Period	tVBP + tVFP	-	-	22	-	-	-	Lines
Vertical Display Area	NTSC	-	-	240		-	-	Lines
	PAL			280(PALM=0)				
	PAL			288(PALM=1)				
Vertical Cycle	NTSC	-	-	262		350	-	Lines
	PAL			313				

7.3 Signal Timing in DE Mode

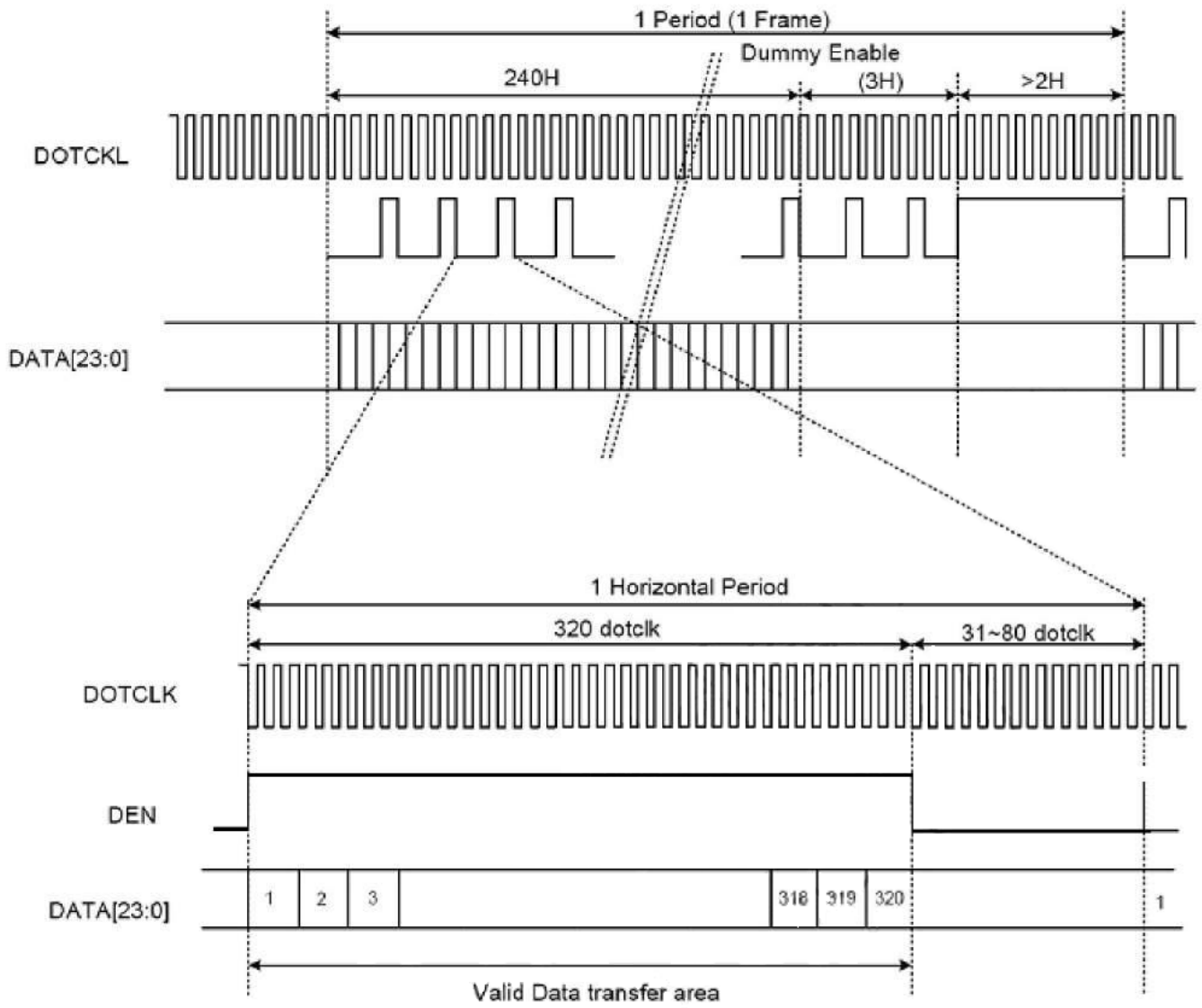

Figure 5: Dummy Enable Mode Signal Timing



8 Power Sequence

8.1 Power Up Sequence

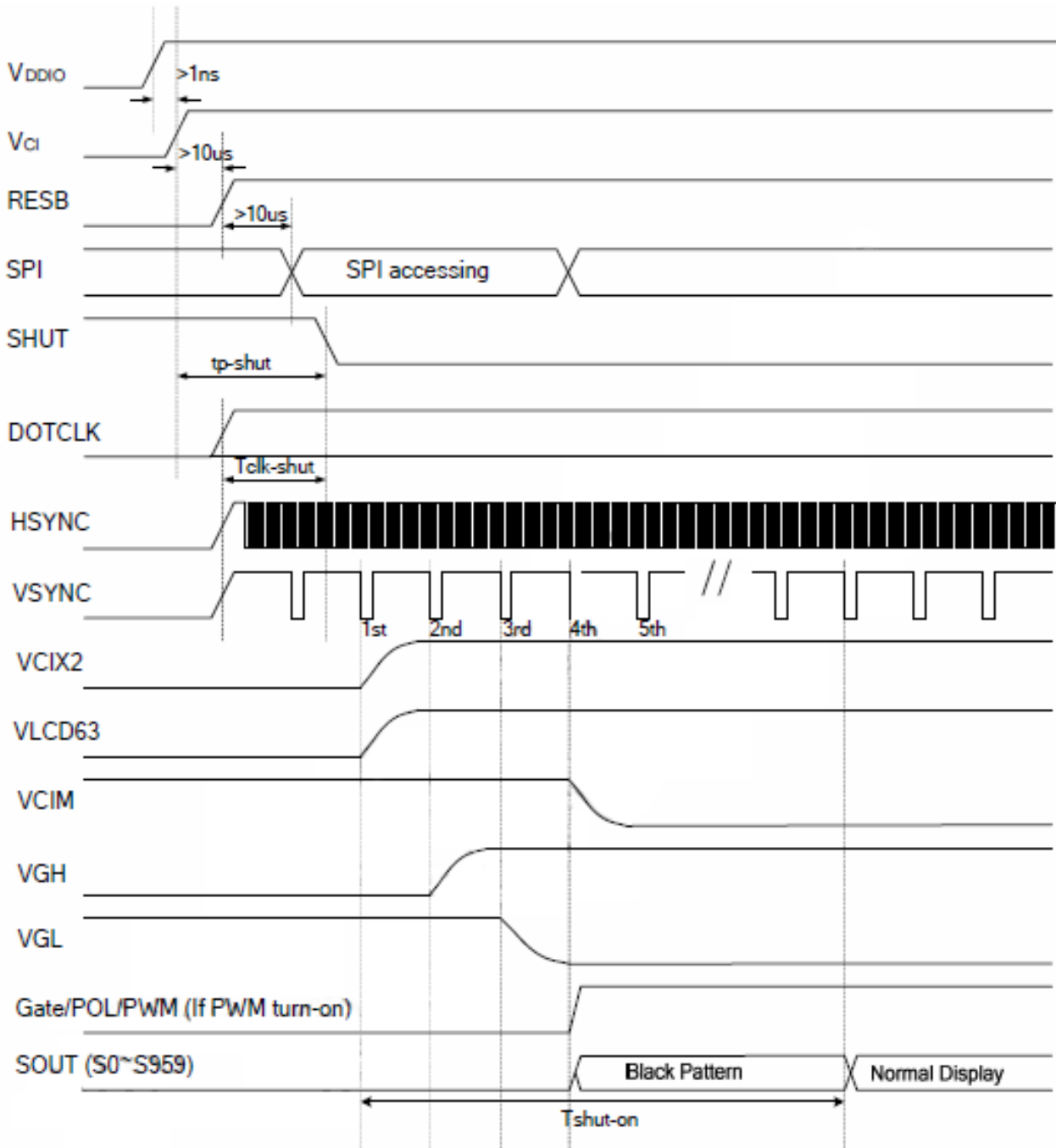

Figure 6: Power Up Sequence

Characteristics	Symbol	Spec.			Unit
		Min.	Typ.	Max.	
VDD/VDDIO on to falling edge of SHUT	tp-shut	1	-	-	μs
DOTCLK	tclk-shut	1	-	-	clk
Falling edge of SHUT to display start	tshut-on	-	-	14	frame
- 1 line: 408 CLK - 1 frame: 262 line - DOTCLK = 6.5MHz		-	166	232.4	ms

***Note:** it is necessary to input DOTCLK before the falling edge of SHUT. Display starts at 10th falling edge of VSYNC after the falling edge of SHUT



8.2 Power Down Sequence

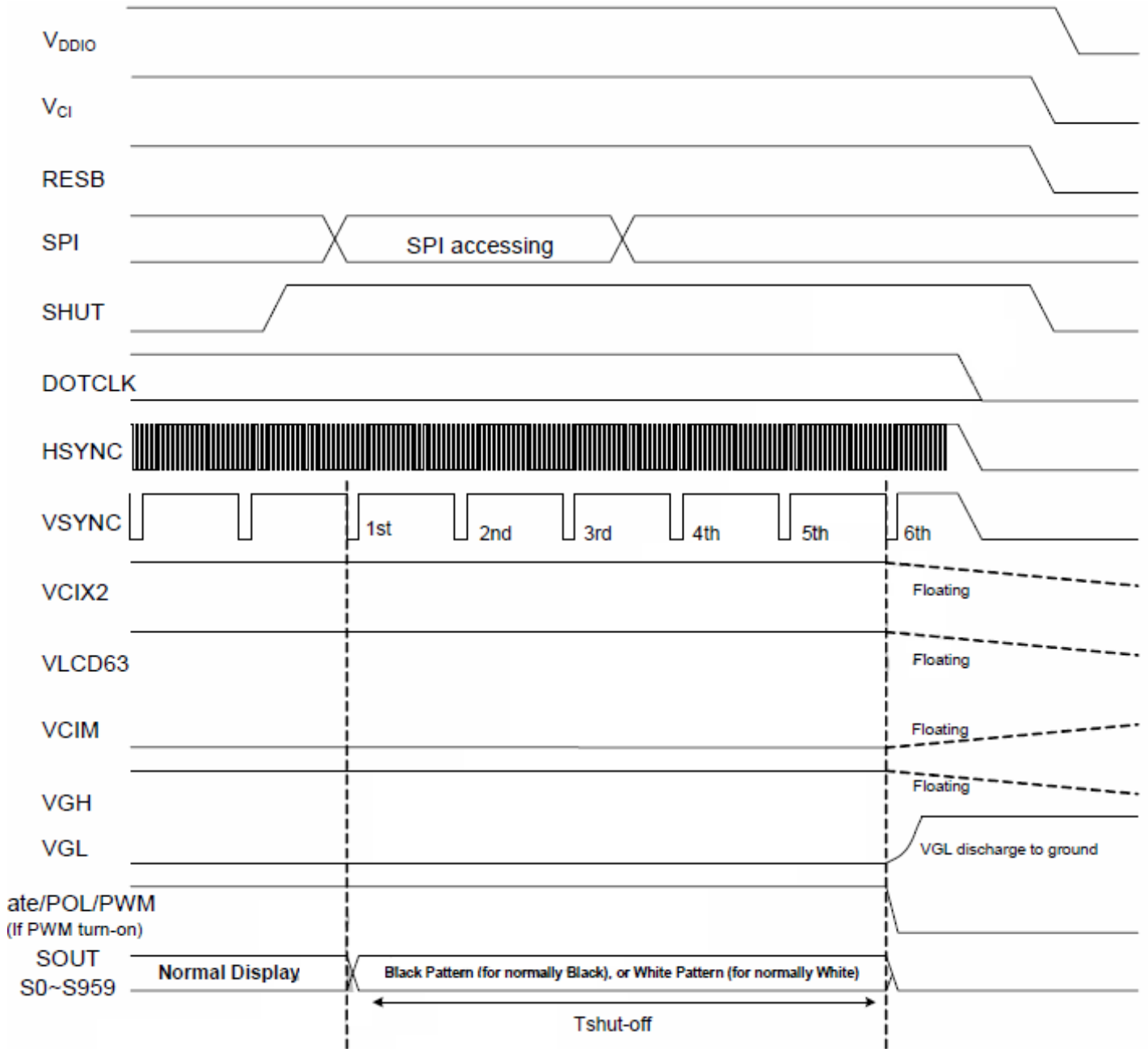

Figure 7: Power Down Sequence

Characteristics	Symbol	Spec.			Unit
		Min.	Typ.	Max.	
Rising edge of SHUT to display off	tshut-off	2	-	-	frame
- 1 line: 408 CLK - 1 frame: 262 line - DOTCLK = 6.5MHz		33.4	-	-	ms

***Note:** DOTCLK must be maintained at least 2 frames after the rising edge of SHUT. Display turns off at the 2nd falling edge of VSYNC after the falling edge of SHUT. If RESET signal is necessary for power down, provide it after the 2- frames-cycle of the SHUT period.



9 Inspection Criterion

9.1 Description

This specification is made to be used as the standard acceptance/rejection criteria for the MOP-TFT320102-29A-BLM-TPN.

9.2 Sample plan

Sampling plan according to GB/T2828.1-2003/ISO 2859-1: 1999 and ANSI/ASQC Z1.4-1993, normal level 2 and based on:

Major defect: AQL = 0.65

Minor defect: AQL = 2.5

Total Defects: AQL = 2.5

9.3 Inspection condition

- Viewing distance for cosmetic inspection is about 30 ± 5 cm with bare eyes, and under 2 20W or 1 40W fluorescent light. All directions for inspecting the sample should be within 45° against perpendicular line. (Normal temperature $25\pm 5^\circ\text{C}$ and normal humidity $65\pm 10\%\text{RH}$).
- During testing, the LCD is driven using the voltage level (Within $\pm 0.5\text{V}$ of the typical value at 25°C .) that provides the most optical contrast

9.4 Definition of inspection zone in LCD

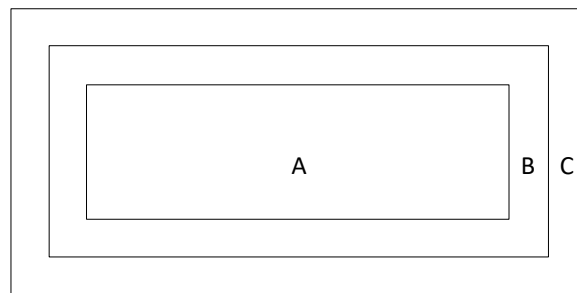

Figure 8: Inspection Zones in an LCD

Zone A: Viewing are

Zone B: Outside Viewing Area

***Note:** As a general rule, visual defects in Zone C are permissible, if it does not affect display quality and assembly of customer's product.

9.5 Function Defect

Items to be inspected	Inspection criterion	Classification of defects
All functional defects	1) No display 2) Display abnormally 3) Missing vertical, horizontal segment 4) Short circuit 5) Back-light no lighting, flickering and abnormal lighting. 6) obvious striation 7) Current beyond specification value	MA
Missing	Missing component	
Outline dimension	Overall outline dimension exceed the drawing is not allowed.	



9.6 LCD pixel defect

(bad dot) (defect type: MI)

Checking item	Judgment criterion
Color bad dot-bright dot(R,G,B)	1
Two adjacent bright point	0
Three or more adjacent point	0
Total points for bad dot-bright dot	1
Bad dot-dark dot	2
Two adjacent dark point	1
Three or more adjacent point	0
Total points for bad dot -dark dot	3
Patch bright dot	Invisible with ND5%, it is OK.

9.7 Dot and line defect

(defect type: MI)

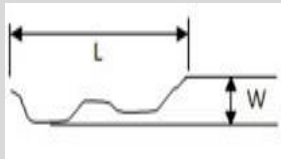
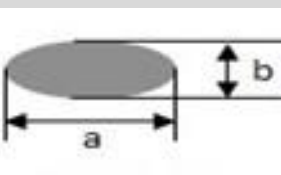
Checking item	Judgment criterion			Figure
	Diameter(mm)\LCD Size		S ≤5.0 Inch	
Line defect	Length(mm)	Width(mm)	Judgement Criterion	
	---	$0.015 \geq W$	allowed	
	$L \leq 3.0$	$0.03 \geq W$	2	
	$L \leq 2.0$	$0.05 \geq W$	1	
	$L \leq 1.0$	$0.1 > W$	1	
	---	$0.05 < W$	Applied as point defect	
Concave point and air bubble for polarizer	Size(mm)		Judgement Criterion	
	$D \leq 0.20$		allowed	
	$0.20 < D \leq 0.25$		3	
	$0.25 < D \leq 0.30$		2	
	$D > 0.30$		0	



10 Handling Precautions

10.1 Mounting method

Do not make extra holes in the display or modify its shape. When mounting the display, ensure that the display does not flex, bend or twist. Extreme care should be used when handling the LCD modules.

10.2 LCD Handling and Cleaning Precaution

To clean the display surface, it is recommended to wipe lightly using a soft cloth with either Isopropyl alcohol or Ethyl alcohol.

Do not wipe the display surface with dry or hard materials as it may damage the polarizer surface.

Do not use Water or Aromatics to clean the display.

Do not wipe ITO pad area with dry or hard materials that will damage the ITO patterns

Do not use Soldering flux, Chlorine(Cl), and Sulfur(S) on the pad or prevent it from being contaminated.

If the display is sent without applying a silicon coat on the pad, the ITO patterns could be damaged due to corrosion as time goes on.

If ITO corrosion occurs due to customer miss-handling, or if the customer applies materials such as Chlorine (Cl), Sulfur (S) to the display, the responsibility is placed the customer.

10.3 Static Charge Precaution

The LCD module uses CMOS LSI drivers, so we recommend that you:

- Connect any unused input terminal to VDD or VSS
- Do not input any signals before power is turned on
- Ground your body, work/assembly areas, and assembly equipment to protect against static electricity.

10.4 Packing

The module employs LCD elements and must be treated as such.

- Avoid intense shock and falls from a height.
- To prevent modules from degradation, do not operate or store them exposed direct to sunshine or high temperature/humidity

10.5 Precautions during Operation

- It is an indispensable condition to drive the LCD module within the specified voltage limits. Applying voltage higher than the limit will reduce the life span of the LCD.
- Using direct drive current should be avoided, as it will induce an electrochemical reaction causing undesirable deterioration.
- The LCD's response time will be delayed when operating at a temperature lower than the suggested operating range. When operating at a temperature higher than the suggested range, the LCD will be noticeably darker. The display will return to normal when it is brought back to the specified operation temperature.
- If the display area is pushed hard during operation, some font may be abnormally drawn but the LCD will return to normal after it is reset.
- Slight dew depositing on terminals can cause an electro-chemical reaction, damaging traces and resulting in an open circuit.

Usage under the maximum operating temperature, 50%Rh or less is required



10.6 Storage Recommendations

When storing the LCD for a prolonged period of time, the following recommendations will help prevent damage or deterioration

- Store the display in an ambient temperature range between 10°C to 30°C, and in a relative humidity of 45% to 75%.
- Do not leave the display exposed to sunlight or fluorescent light.
- Place the display in a polyethylene bag with the opening sealed.
- Ensure that nothing is making contact with the polarizer surface.
- It is recommended to store them in the same packaging that was provided upon purchase

10.7 Safety Precautions

In the case that the LCD glass has shattered, it is recommended to remove any glass pieces, wash off the liquid crystal using either acetone or ethanol, and proceed to burn any remaining display pieces.

If any liquid leaked out of a damaged glass cell, and comes in contact with your hands, please wash it off well with soap and water



11 Ordering

11.1 Part Numbering Scheme

Table 1: Parallel TFT Part Numbering Scheme

MOP	TFT	320	102	29	A	BLM	TPN
1	2	3	4	5	6	7	8

11.2 Options

Table 2: Parallel Part Options

#	Designator	Options
1	Product Line	MOP: Matrix Orbital Parallel Display
2	Screen Type	TFT: Graphic TFT
3	Display Columns	320: Three Hundred Twenty Pixel Columns
4	Display Rows	102: One Hundred Two Pixel Rows
5	Display Size	29: 2.9"
6	Display Form Factor	A: A Form Factor
7	Brightness Level	-BLS: Brightness < 300 Nit -BLM: 300 Nit < Brightness < 600 Nit -BLH: 600 Nit < Brightness < 1000 Nit -BLD: Brightness > 1000 Nit
8	Touch Panel Type	TPN: None TPR: Resistive TPC: Capacitive

12 Contact

Sales

Phone: 403.229.2737

Email: sales@matrixorbital.ca

Support

Phone: 403.204.3750

Email: support@matrixorbital.ca

Online

Purchasing: www.matrixorbital.com

Support: www.matrixorbital.ca

